

# 0.4mm Pitch Ultra-low Profile FPC Back-lock Connector [Upper Contact]

RoHS2

## FF18 Series

Fujikura

### OUTLINE

FF18 series is a connector with a cable lock mechanism to provide positive retention of the FPC. This LIF connector has a dedicated upper contact to interface with the FPC at a 0.4mm pitch. The ultra-low profile connector has a 0.66mm height, making it one of the smallest board mounted FPC LIF connectors on the market.

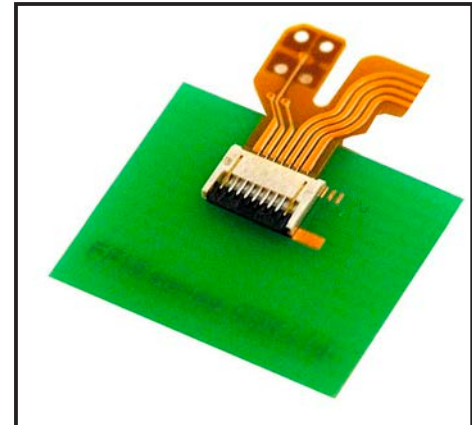

### FEATURE

- Original cam-type back-lock system provides reliable operation and ensures retention from inadvertent upward pulling of the FPC.
- The FF18 LIF connector utilizes a cable lock mechanism to provide positive retention of the FPC.
- Back-lock mechanism ensures retention from inadvertent from upward pulling of the FPC.
- These ZIF connectors are delivered with the lock lever opened for maximum production efficiency.
- Available in pin counts for this low profile connector are 4, 5, 6, 7, 8, 9 and 10.
- High-temperature resin for lead free reflow process.
- FF18 ZIF connectors are delivered in a tape and reel package for automated machine processes .

Note : Please do not close the lock lever without inserting the FPC.

Since cable lock tabs electrify next contacts, please do not use the cable lock tabs as ground tabs.

### APPLICATIONS

Mobile phone, notebook PC, PDA, other Portable devices

### SPECIFICATIONS

Rated Voltage	50V AC (r.m.s.)
Rated Current	0.4A / Contact
Dielectric Withstand Voltage	200V AC (r.m.s.) / 1 minute
Insulation Resistance	100 M $\Omega$ min. at 500V DC
Contact Resistance	50m $\Omega$ max.

### MATERIAL/FINISH



Item	Material / Finish
Conatct	Copper Alloy / Au (Flash) over Ni
Housing	LCP Resin (UL94V-0) / Black
Lock lever	PPS Resin (UL94V-0) / Black

© Specifications and/or dimensions in this catalogue are subject to change without notice.  
Your catalogue checking the latest specifications with our drawings would be highly appreciated.

251226

<https://www.connector.fujikura.com>

▶ 0.4mm Pitch FPC Back-lock Connector

**FF18- □□ A-R11AD-B-3J**

① ② ③ ④ ⑤ ⑥ ⑦ ⑧ ⑨ ⑩

① Series	FF18
② Number of Contact	Refer to th table 1
③ Contact Position	A : Upper Contact Applicable PCB Thickness : 0.12±0.03mm
④ Contact Style	R : Right Angle
⑤ Contact Tail Length	1 : 0.40mm
⑥ Contact Plating	1 : Au (Flash) over Ni
⑦ Slider Form	A : Standard
⑧ Ni barrier	D : With Ni barrier
⑨ Color	B : Black
⑩ Material	3J : Halogen-free,PFAS Free

Dimensions

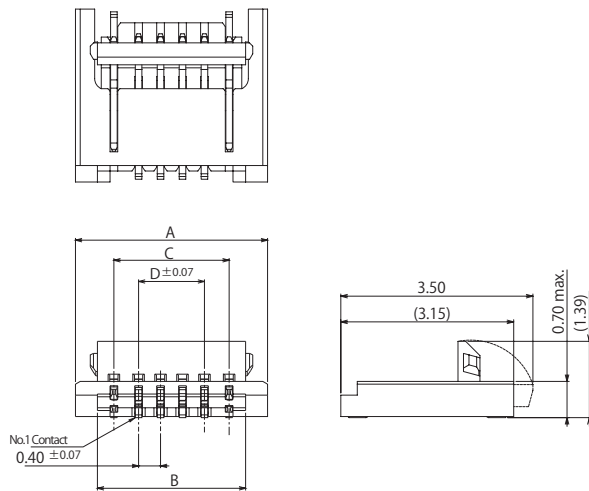

Recommended PCB Mounting Dimensions

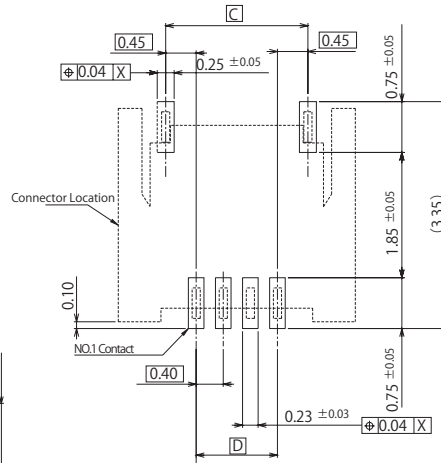

Recommended FPC Dimensions

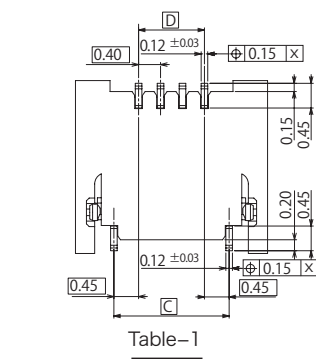
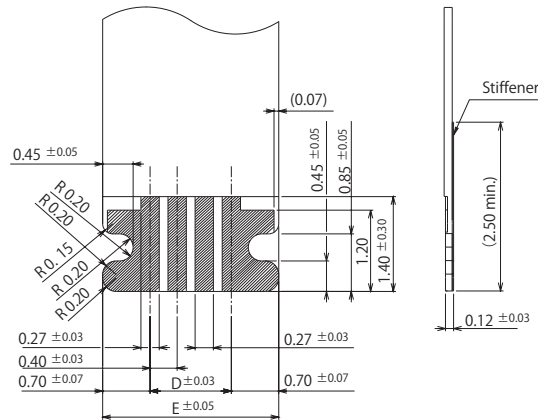

Table-1



Part Number	Number of Contact	A	B	C	D	E
FF18- 4A-R11AD-B-3J	4	3.50	2.70	2.10	1.20	2.60
FF18- 5A-R11AD-B-3J	5	3.90	3.10	2.50	1.60	3.00
FF18- 6A-R11AD-B-3J	6	4.30	3.50	2.90	2.00	3.40
FF18- 7A-R11AD-B-3J	7	4.70	3.90	3.30	2.40	3.80
FF18- 8A-R11AD-B-3J	8	5.10	4.30	3.70	2.80	4.20
FF18- 9A-R11AD-B-3J	9	5.50	4.70	4.10	3.20	4.60
FF18- 10A-R11AD-B-3J	10	5.90	5.10	4.50	3.60	5.00

© Specifications and/or dimensions in this catalogue are subject to change without notice.  
Your catalogue checking the latest specifications with our drawings would be highly appreciated.

► Package Specifications

■ Reel Dimensions

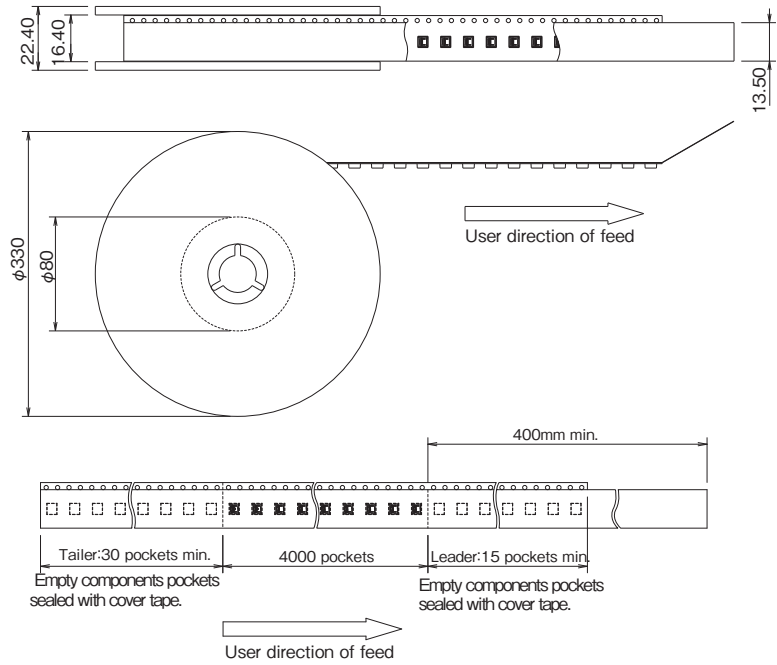

■ Emboss Tape Dimensions

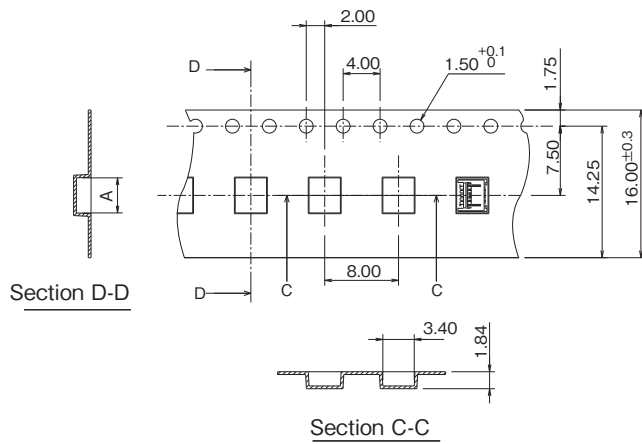

■ Quantity : 4000pcs./reel

Part Number	Number of Contacts	A
FF18- 4A-R11AD-B-3J	4	3.80
FF18- 5A-R11AD-B-3J	5	4.20
FF18- 6A-R11AD-B-3J	6	4.60
FF18- 7A-R11AD-B-3J	7	5.00
FF18- 8A-R11AD-B-3J	8	5.40
FF18- 9A-R11AD-B-3J	9	5.80
FF18- 10A-R11AD-B-3J	10	6.20

© Specifications and/or dimensions in this catalogue are subject to change without notice.  
Your catalogue checking the latest specifications with our drawings would be highly appreciated.

▶ Operating Instruction and Cautions

# 1. Connector mounting Instruction

Connectors are delivered with a lock lever opened.  
 You do not have to operate the lock lever before inserting FPC.  
 (picture ①)

Please do not re-flow with the lock lever closed condition.  
 Please close the lock-lever with inserting FPC, otherwise  
 the contact gap become narrower and FPC insertion force will rise.  
 (picture ②)

Please do not load (0.5N×pin Min.) from the top of the lock lever.  
 (figure ①) And please do not load (0.5N×pin Min) toward the opposite  
 direction of the lock lever, (figure ②)  
 otherwise the lock lever may be broken or contacts may be deformed.

Lock lever is opened when delivery.

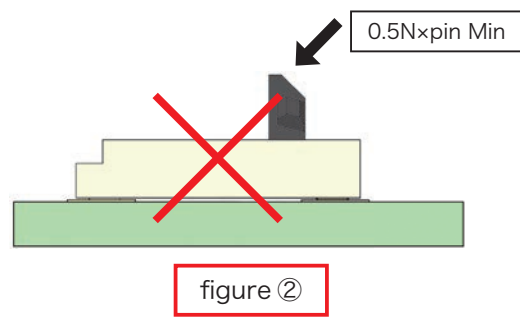
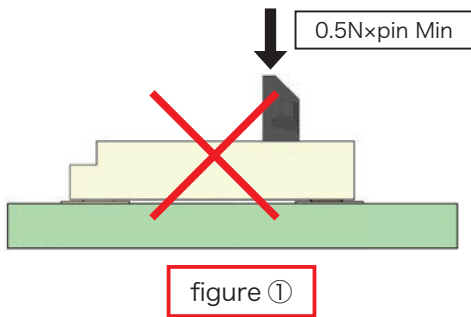
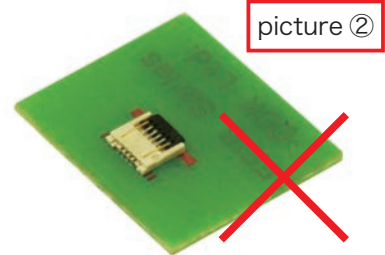
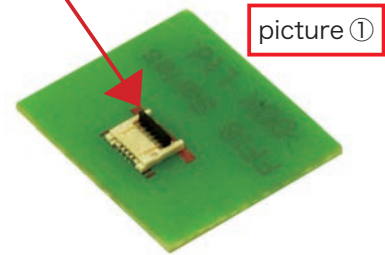

While FPC mated with connector, cable lock tabs conduct to both ends of contacts.  
 Please do not ground the cable lock tab pad on the mounting board. (figure: ③)

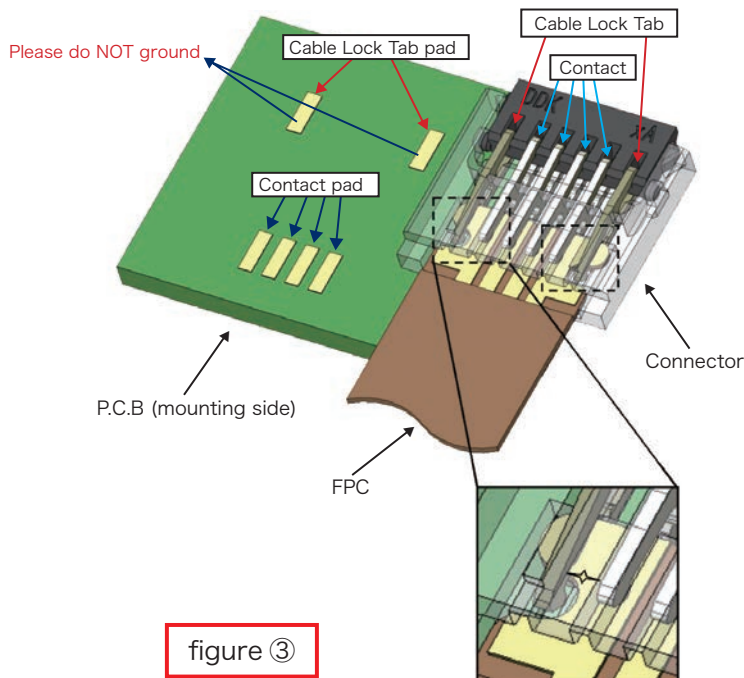

© Specifications and/or dimensions in this catalogue are subject to change without notice.  
 Your catalogue checking the latest specifications with our drawings would be highly appreciated.

▶ Operating Instruction and Cautions

## 2. FPC Insertion

Please insert FPC to the pattern side up.(picture ③④)

Please insert FPC straight to the connector.

Due to the semi-retaining mechanism, some insertion force is necessary when inserting FPC.

Please make sure whether FPC is inserted fully.

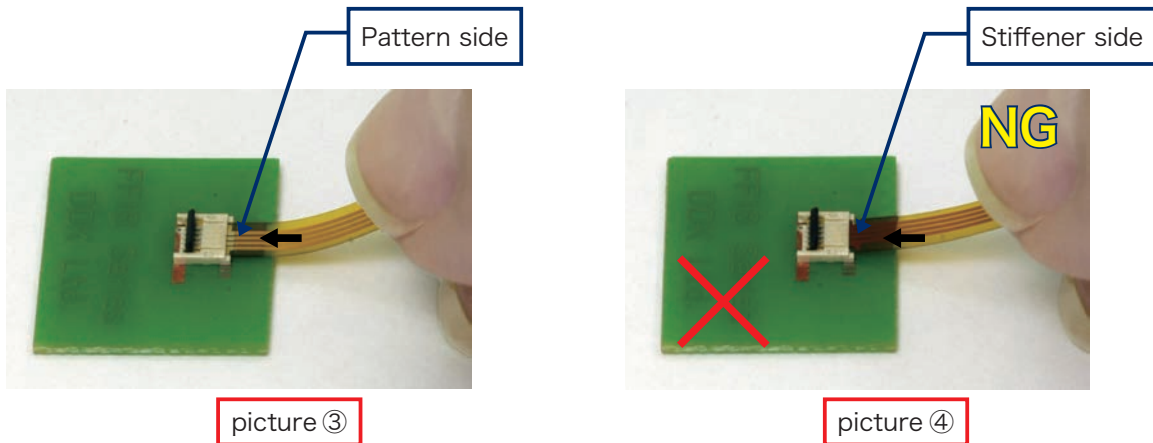

## 3. Correct FPC Insertion Position

As illustrated (picture ⑤ ), you can check short insertion(picture ⑥ ) and diagonal insertion(picture ⑦ ) by checking the position of connector housing and FPC positioning edge.

If the FPC positioning edge is exposed from the connector housing, it may be short insertion or diagonal insertion. Please re-insert FPC fully.

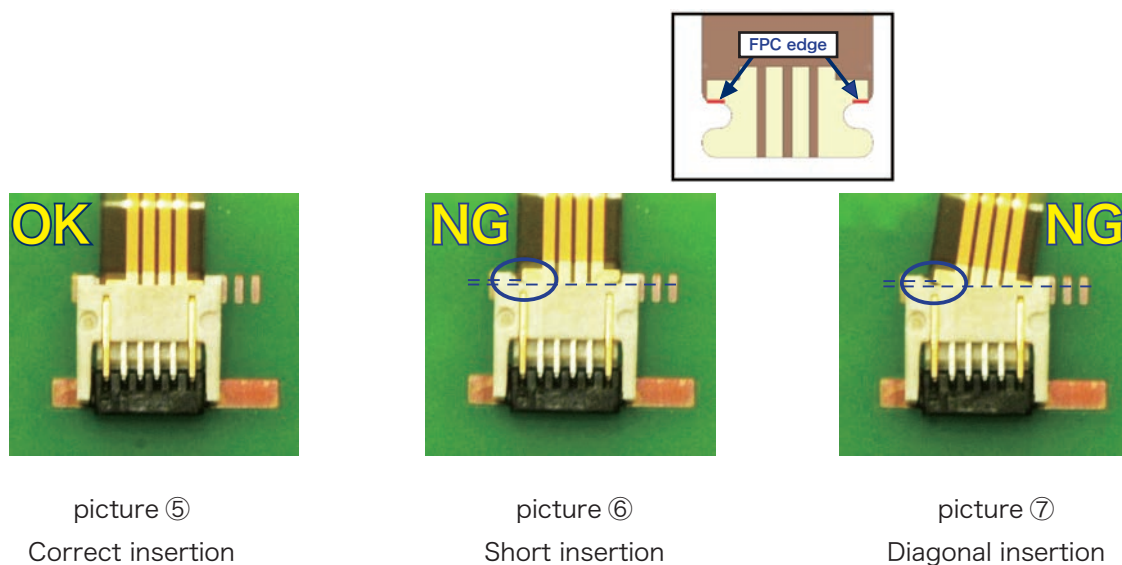

▶ Operating Instruction and Cautions

### 4. Closing Lock Lever

Please rotate down the lock lever until firmly closed. (picture ⑧)

Please do not load excessive force(3N Min) on the housing(picture ⑨)

and please do not close the lock lever by tip of a nail.(picture ⑩)

It may cause breakage of the lock lever.

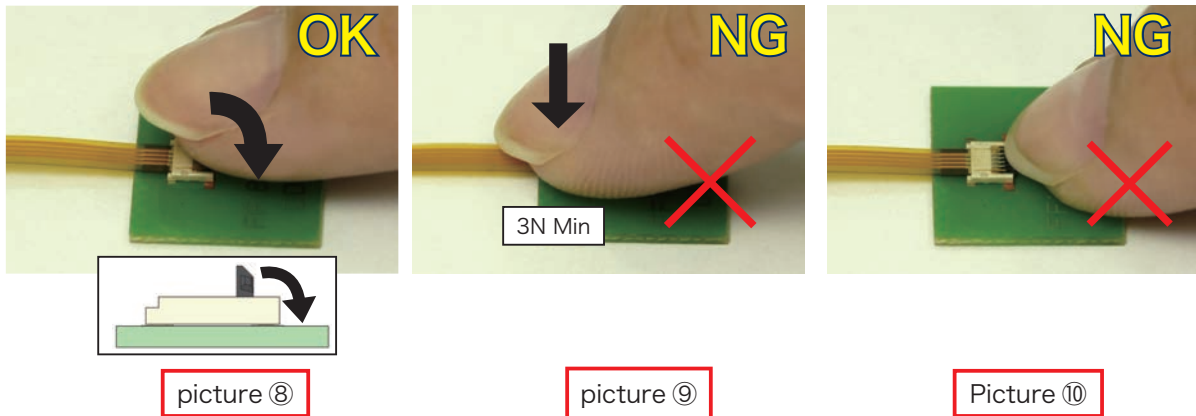

### 5. Removing FPC

Please lift the lock lever like flipping up in the direction of arrow.(picture ⑪)

Please do not load excessive force (0.5N×pin Min.) on the lock lever.(picture ⑫)

When operating the lock lever, please make sure to not catch to the connector housing.

It may cause breakage of the housing (figure ④).

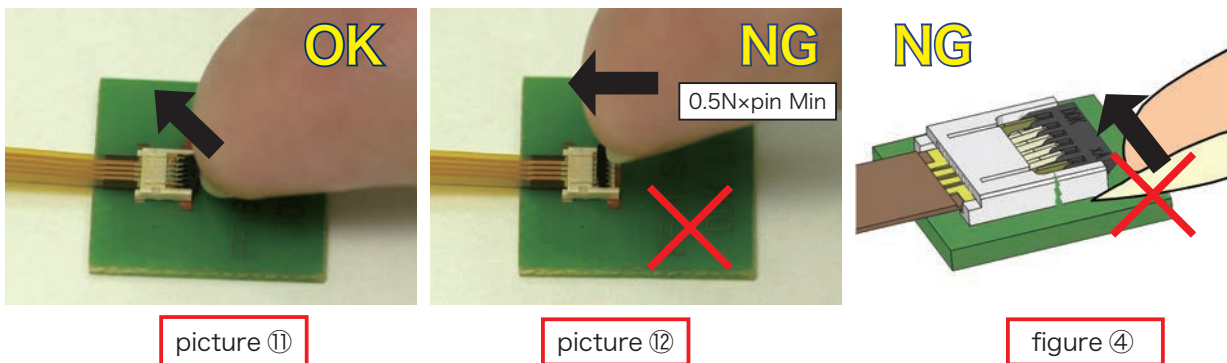

### 6. E S D (Electrostatic Discharge)

This connector is not taken ESD measure.

### 7. Disposal of Connector

Please dispose the connector as industrial waste.

© Specifications and/or dimensions in this catalogue are subject to change without notice.  
Your catalogue checking the latest specifications with our drawings would be highly appreciated.